



SUMMERSET

PROFESSIONAL GRILLS

44" - TRLD

Model	TRLD44
Cutout Dimensions**	45.25"W x 11"H x 20"D
Actual Dimensions	46.654"W x 23.779"H x 25.551"D
Material	#304 Stainless Steel
Burner Count	4 Main Burner
Total BTU	95,000 BTU
Total Cooking Surface	1,251 sq. in.
Electical Supply	120 VAC, 60 HZ - Input 12 VAC, 5000 mA, 60W - Output
Gas Inlet NG	3/8" NPT Female Regulator
Gas Inlet LP	3/8" NPT Male Fitting
Power Cord Length	13 ft. : 77" Power Cord + 80" Trans Wire

Front

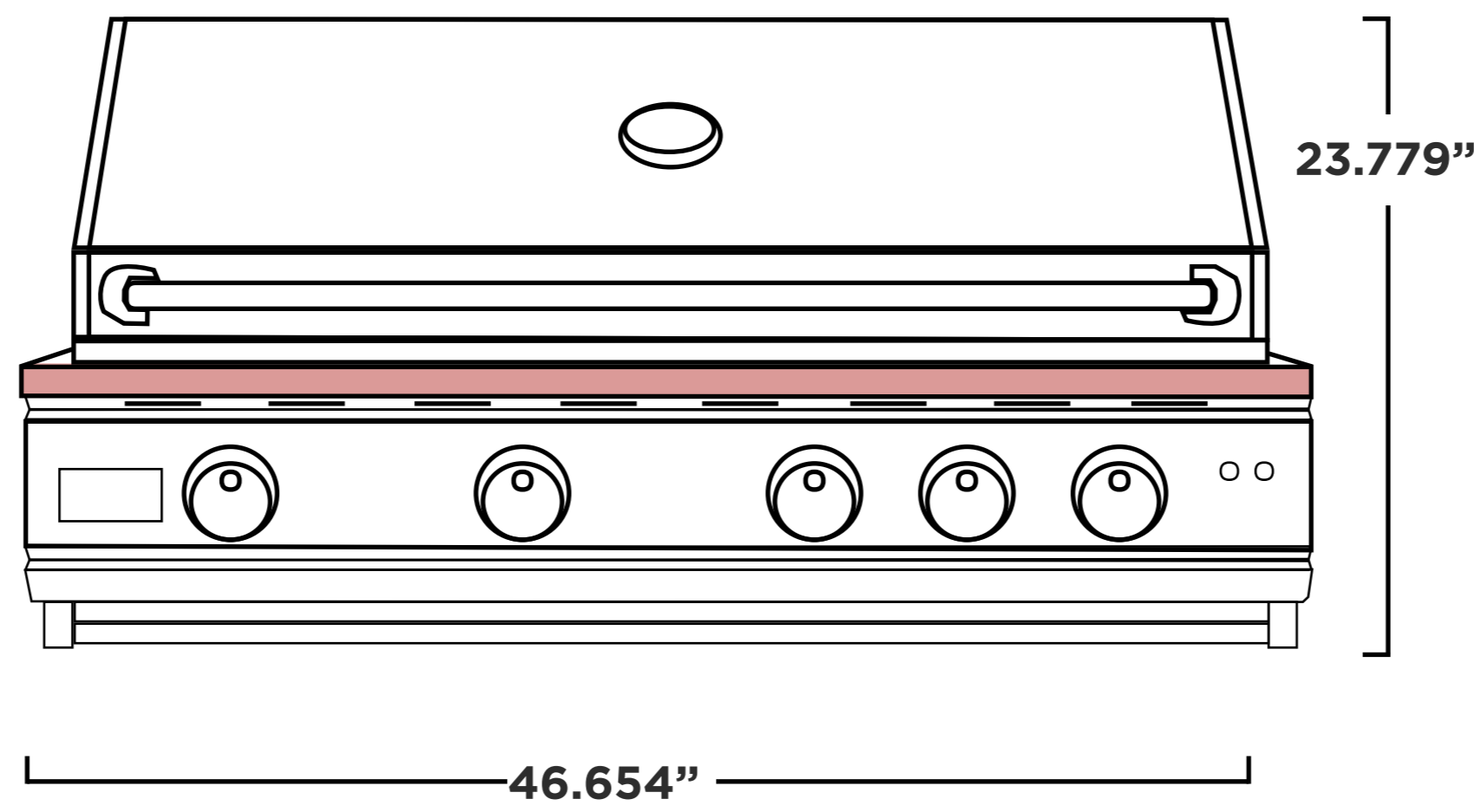

Rear

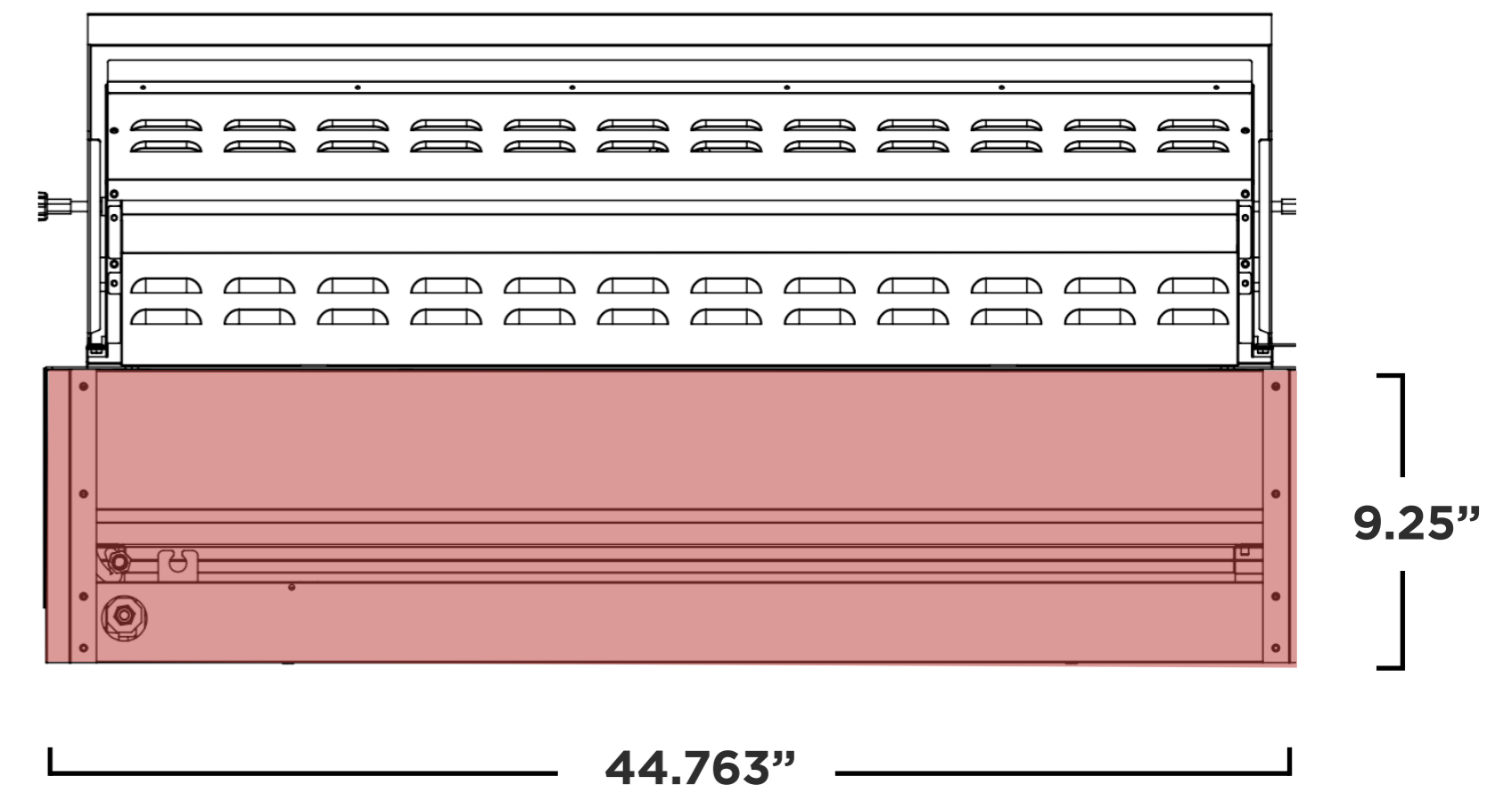

Side

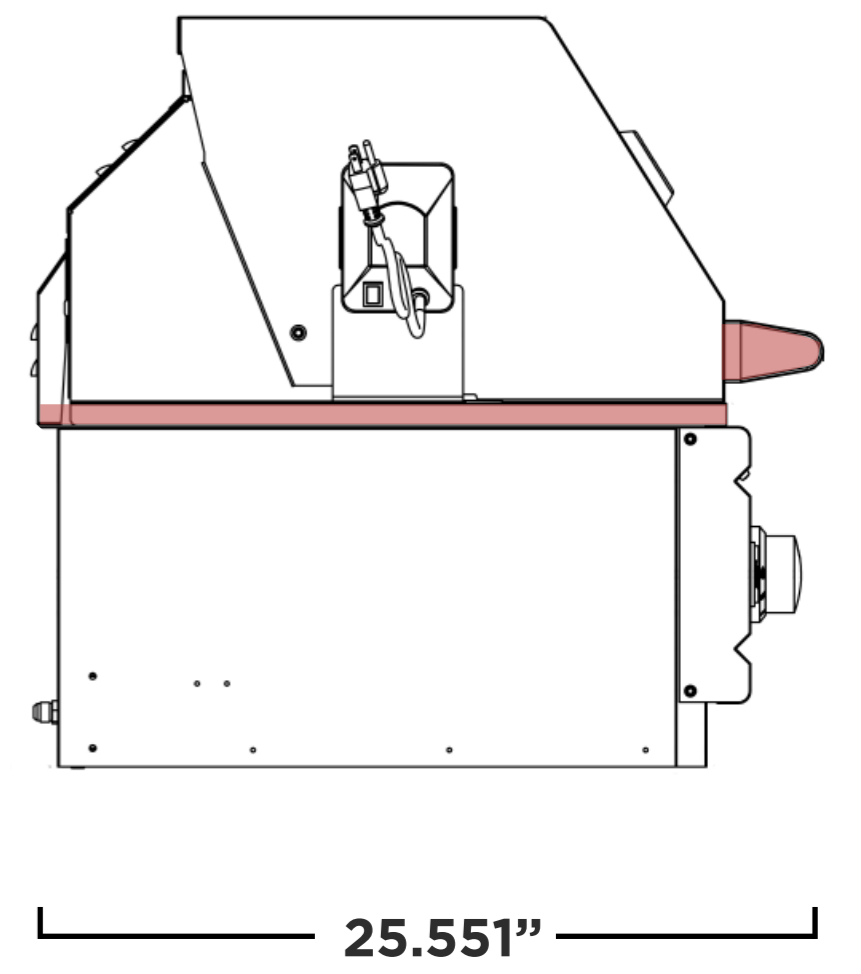
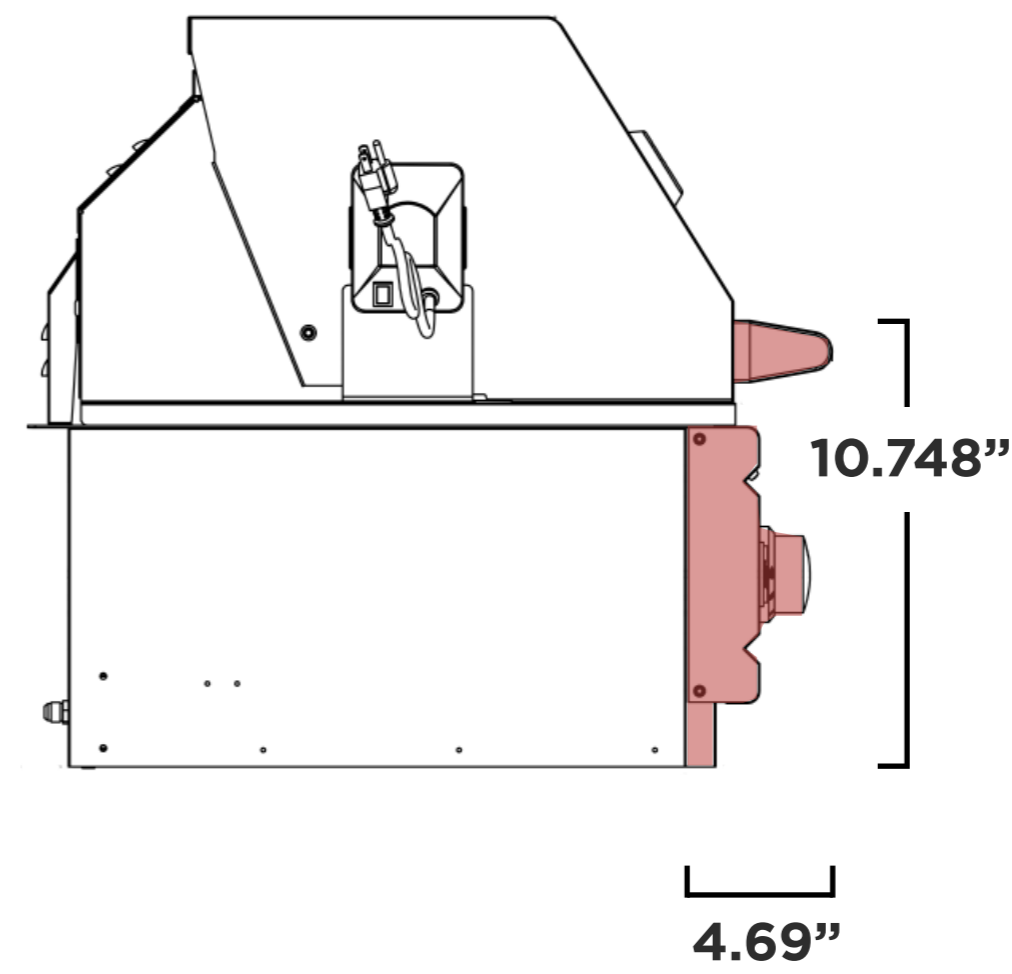
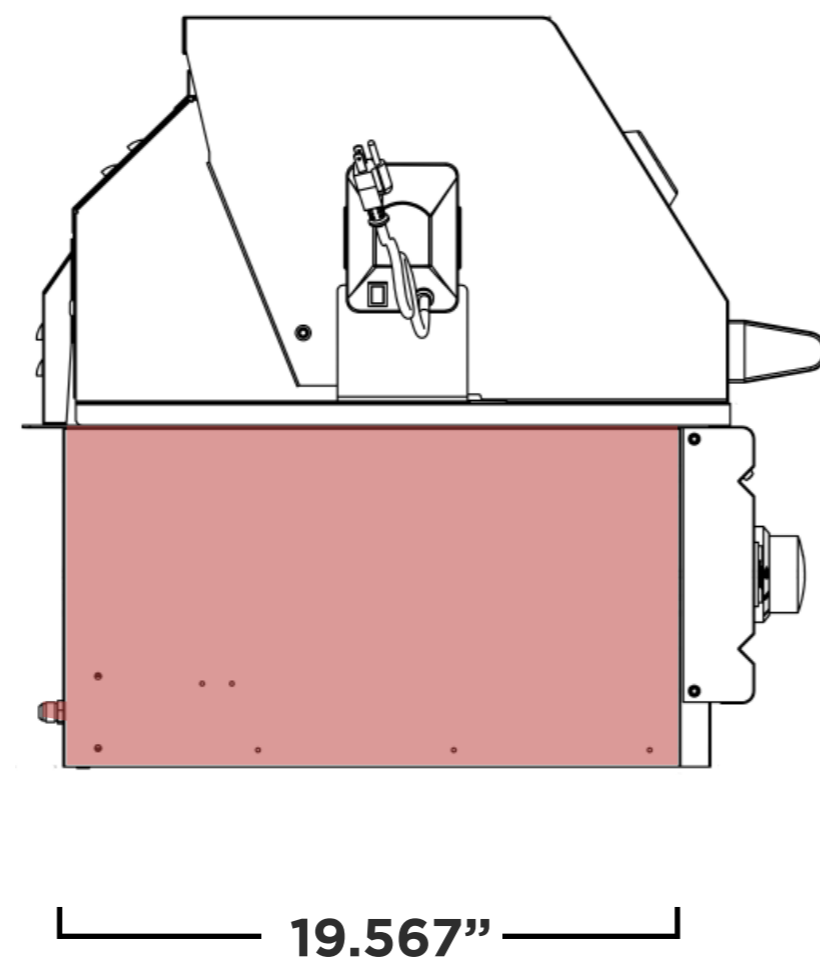

NOTES

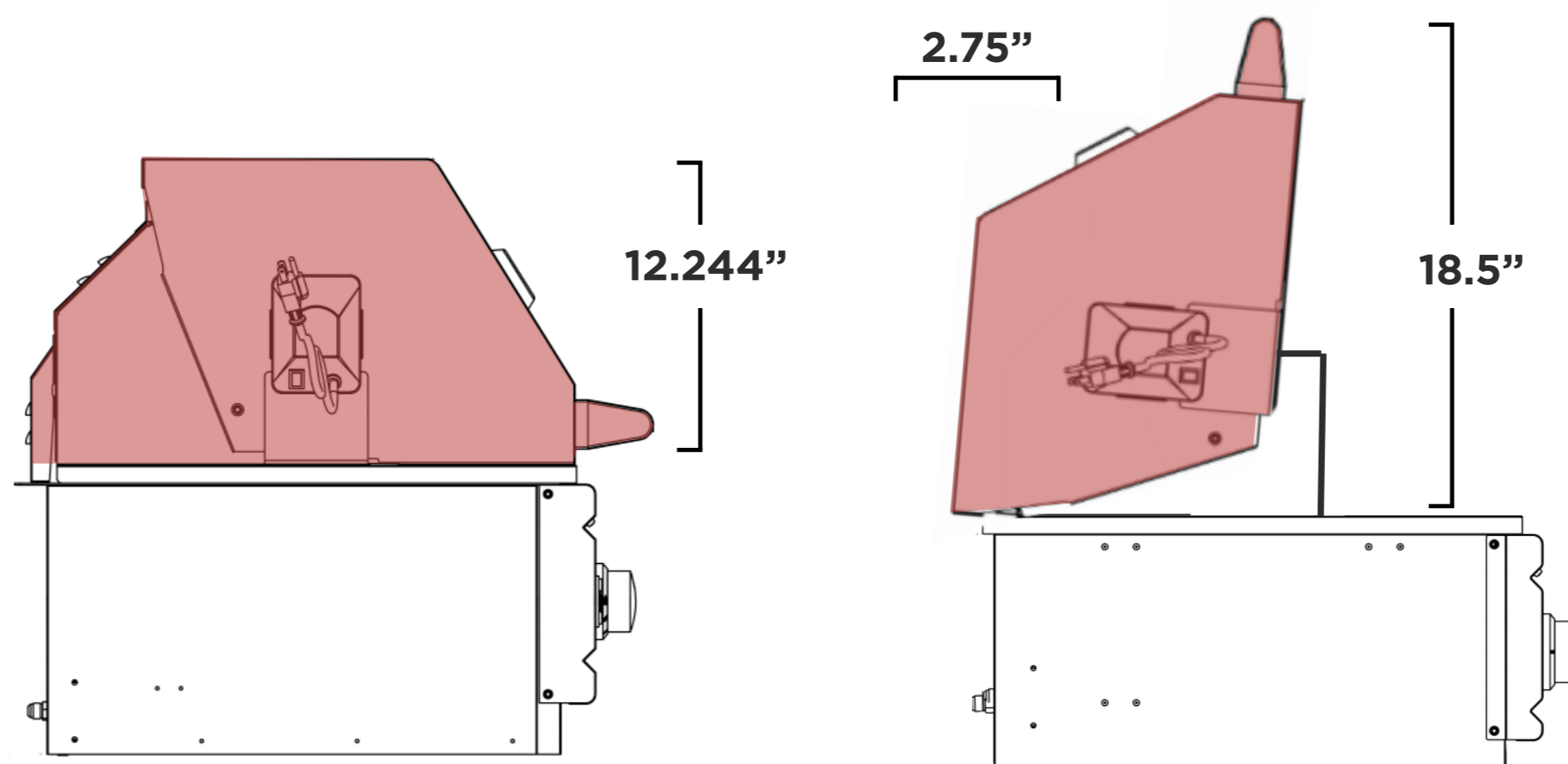

Cutout Dimensions **
45.25"W x 11"H x 20"D

Island Top View

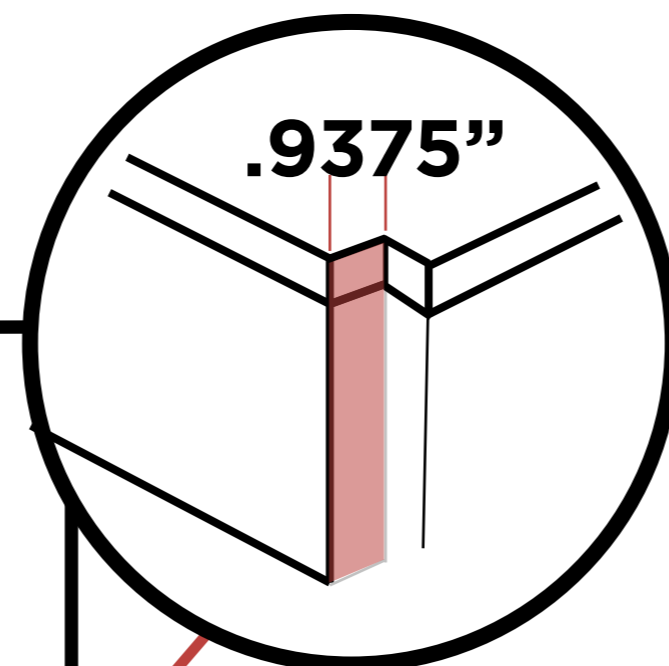
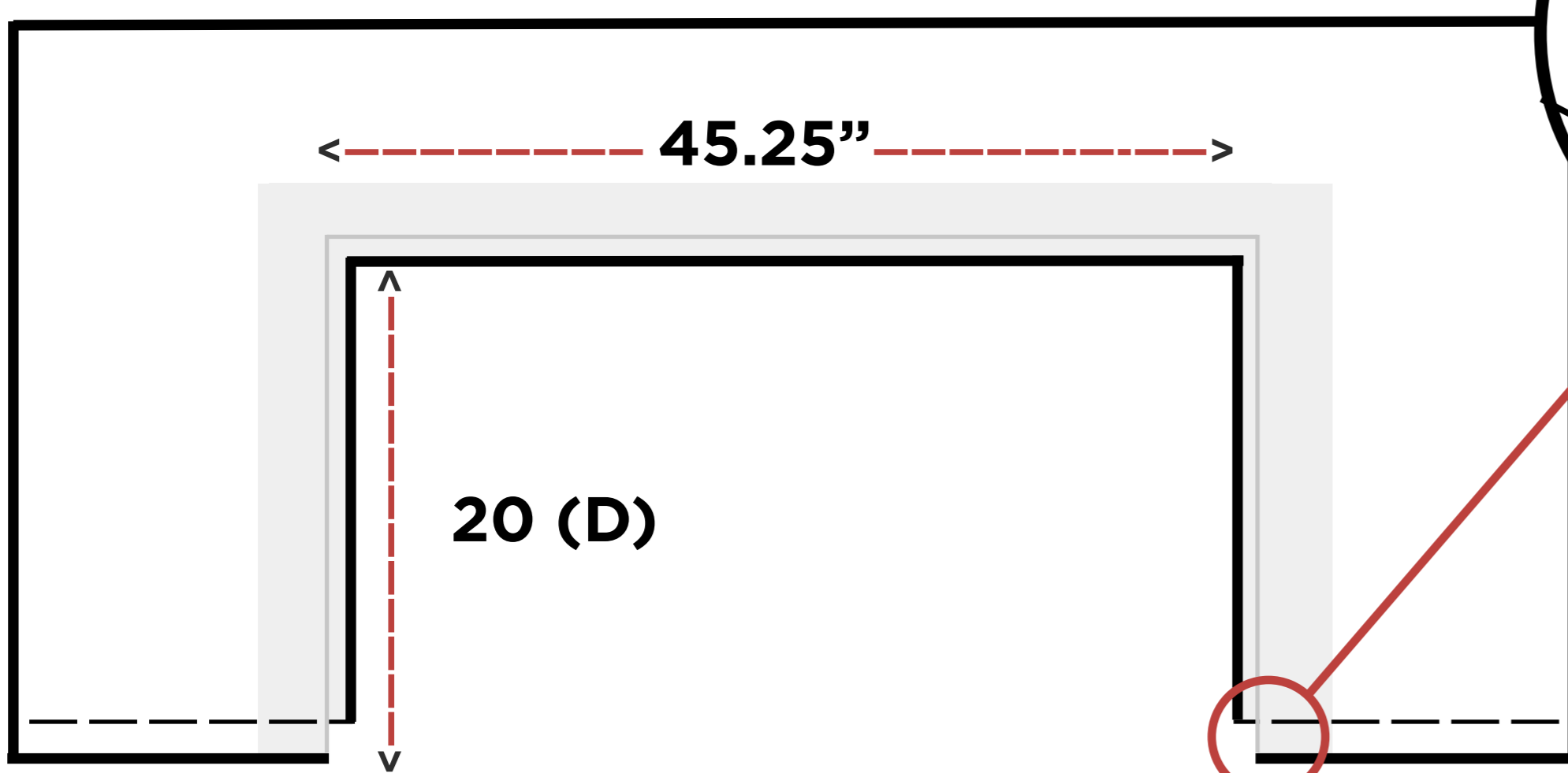

Countertop Notch
Cutout Dimension

Island Front View

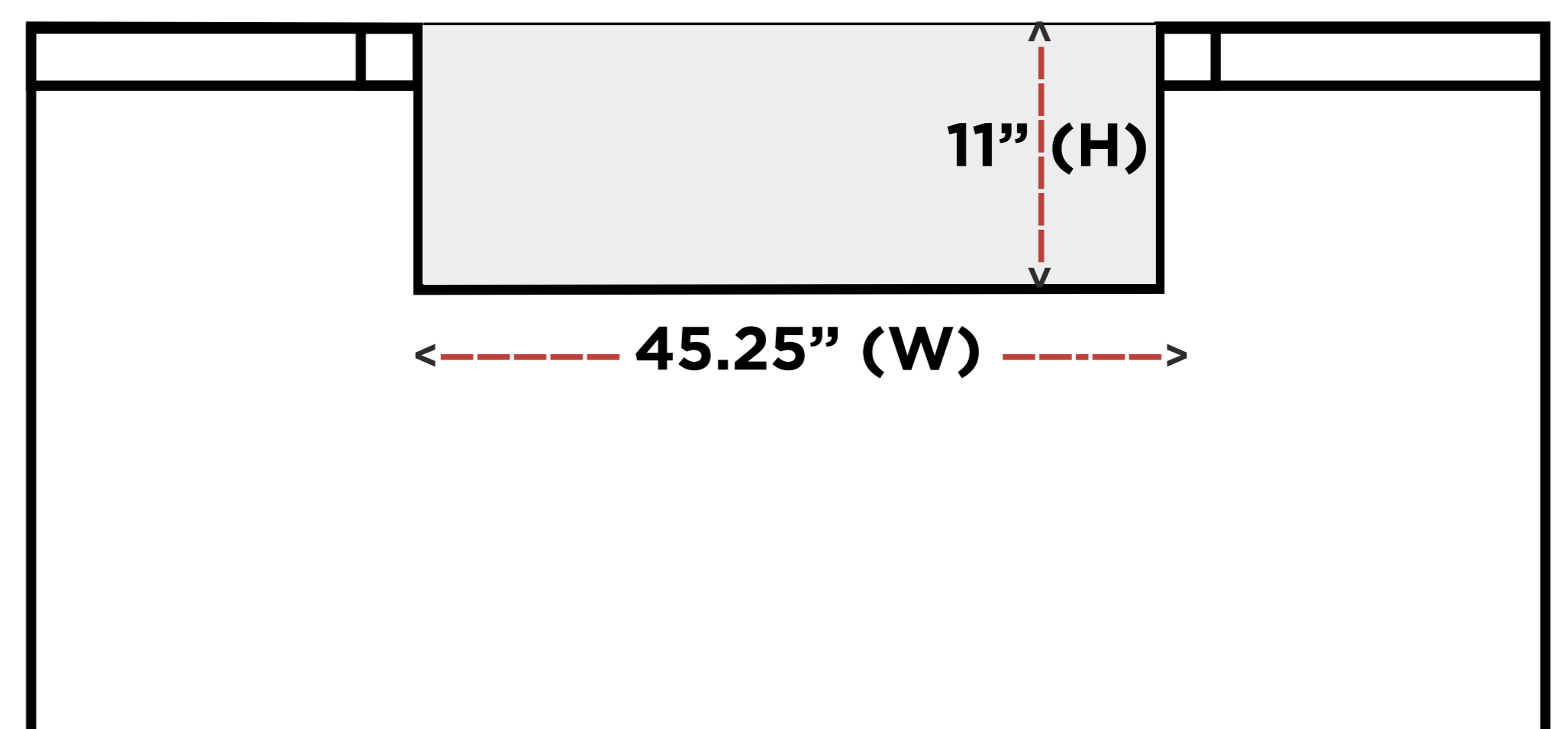

Manufacturer Suggested Cutout Dimensions (**)